

Solenoid Controlled Relief Valves

These valves are a combination of a pilot operated relief valve and a solenoid operated directional valve. Piping between the two is eliminated as the solenoid valve is directly mounted on the relief valve and connected with the relief valve vent. Pump pressure may be unloaded remotely by an electrical signal to the solenoid, or by connecting pilot relief valves to the solenoid valve ports.

Specifications

Model Numbers	Max. Operating Pressure MPa (PSI)	Pressure Adj. Range MPa (PSI)	Max. Flow L/min (U.S.GPM)	Approx. Mass kg (lbs.)		
				Double Sol.	Single Sol.	With Vent Restrictor
Threaded Connection	25 (3630)	Note) ★-25 (★-3630)	100 (26.4)	7.1 (15.7)	6.6 (14.6)	7.6 (16.8)
			200 (52.8)	7.1 (15.7)	6.6 (14.6)	7.6 (16.8)
			400 (106)	10.8 (23.8)	10.3 (22.7)	11.3 (24.9)
Sub-plate Mounting	25 (3630)	Note) ★-25 (★-3630)	100 (26.4)	6.8 (15.0)	6.3 (13.9)	7.3 (16.1)
			200 (52.8)	7.7 (17.0)	7.2 (15.9)	8.2 (18.1)
			400 (106)	11.0 (24.3)	10.5 (23.2)	11.5 (25.4)

Note: For relief valves, standard pilot operated relief valves are used.
For minimum adjustment pressures and other characteristics, see [page 214](#).

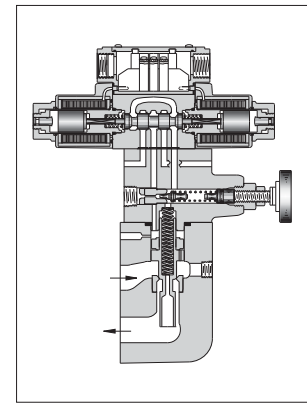
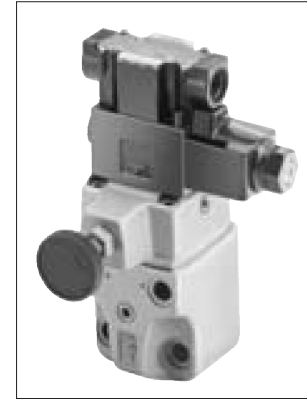

Model Number Designation

F-	A-	BS	T	-03	-V	-2B3A	-A100	-N	-48	*
Special Seals	With Vent Restrictor	Series Number	Type of Mounting	Valve Size	High Venting Pres. Feature	Vent Type	Coil Type ^{★4}	Type of Electrical Con.	Design Number	Design Standards
F: Special Seals for Phosphate Ester Type Fluids (Omit if not required)	A: With Vent Restrictor (Option-Omit if not required) ^{★1}	BS: Solenoid Controlled Relief Valves	T: Threaded Connection G: Sub-plate Mounting	03 06 10	V: For High Venting Pressure Feature (Omit if not required) ^{★2}	2B3A ^{★3} 2B3B 2B2B 2B2 3C2 3C3	AC: A100, A120, A200, A240 DC: D12, D24, D48 AC→DC: R100, R200	None: Terminal Box Type N: With Plug-in Connector (DIN) N: With Plug-in Connector (DIN)	48	None: Japanese Std. "JIS" 90: N. American Design Std. 80: European Design Std.

- ★1. Models with vent restrictor are applicable only for the vent type 2B3A and 2B3B. For details, see [page 222](#).
- ★2. Use high venting pressure types to reduce response time from unloading to onloading.
- ★3. For the details of the vent types, see the [following page](#).
- ★4. The coil codes are the same as for solenoid operated directional valve DSG-01. See the Solenoid Ratings on [page 345](#).

The coil type numbers in the shaded column are handled as optional extras. In case these coils are required to be chosen, please confirm the time of delivery with us before ordering.

Vent Types

Vent Type	Graphic Symbols	Solenoid Operated Directional Valve Model Number	Operation		
			SOL "a"	SOL "b"	Vent Connecting
2B3A		DSG-01-2B3A	—	OFF	Connected to port "A".
			—	ON	Connected to tank (no-load)
2B3B		DSG-01-2B3B	—	OFF	Connected to tank (no-load)
			—	ON	Connected to port "B".
2B2B		DSG-01-2B2B	—	OFF	Closed state (relief valve setting pressure)
			—	ON	Connected to port "B".
2B2		DSG-01-2B2	—	OFF	Connected to port "A".
			—	ON	Connected to port "B".
3C2		DSG-01-3C2	OFF	OFF	Closed state (relief valve setting pressure)
			ON	OFF	Connected to port "A".
			OFF	ON	Connected to port "B".
3C3		DSG-01-3C3	OFF	OFF	Connected to tank (no-load)
			ON	OFF	Connected to port "A".
			OFF	ON	Connected to port "B".

C
Solenoid Controlled Relief Valves

Attachment

Mounting Bolts

Valve Model Numbers	Socket Head Cap Screw	
	Japanese Std. "JIS" and European Design Std.	N. American Design Std.
BSG-03	M12 × 70 Lg. (2 pcs.), M12 × 95 Lg. (2 pcs.)	1/2-13UNC × 2-3/4 Lg. (2 pcs.), 1/2-13UNC × 3-3/4 Lg. (2 pcs.)
BSG-06	M16 × 60 Lg. (2 pcs.), M16 × 80 Lg. (2 pcs.)	5/8-11UNC × 2-1/4 Lg. (2 pcs.), 5/8-11UNC × 3-1/4 Lg. (2 pcs.)
BSG-10	M20 × 70 Lg. (2 pcs.), M20 × 90 Lg. (2 pcs.)	3/4-10UNC × 2-3/4 Lg. (2 pcs.), 3/4-10UNC × 3-1/2 Lg. (2 pcs.)

Sub-plate

Valve Model Numbers	Japanese Standard "JIS"		European Design Standard		N. American Design Standard		Approx. Mass kg (lbs.)
	Sub-plate Model Numbers	Thread Size	Sub-plate Model Numbers	Thread Size	Sub-plate Model Numbers	Thread Size	
BSG-03	BGM-03-20	Rc 3/8	BGM-03-3080	3/8 BSP.F	BGM-03-2090	3/8 NPT	2.4(5.3)
	BGM-03X-20	Rc 1/2	BGM-03X-3080	1/2 BSP.F	BGM-03X-2090	1/2 NPT	3.1(6.8)
BSG-06	BGM-06-20	Rc 3/4	BGM-06-3080	3/4 BSP.F	BGM-06-2090	3/4 NPT	4.7(10.4)
	BGM-06X-20	Rc 1	BGM-06X-3080	1 BSP.F	BGM-06X-2090	1 NPT	5.7(12.6)
BSG-10	BGM-10-20	Rc 1-1/4	BGM-10-3080	1-1/4 BSP.F	BGM-10-2090	1-1/4 NPT	8.4(18.5)
	BGM-10X-20	Rc 1-1/2	BGM-10X-3080	1-1/2 BSP.F	BGM-10X-2090	1-1/2 NPT	10.3(22.7)

- Sub-plates are available. Specify the sub-plate model number from the table above. When sub-plates are not used, the mounting surface should have a good machined finish.
- The sub-plates are those for pilot operated relief valves. For dimensions, see [page 213](#).

Option

Models with vent restrictor

The type with a vent restrictor has a vent restrictor in vent types 2B3A and 2B3B added between a relief valve and a solenoid operated directional valve. It prevents shock to the main circuit by gradually lowering the venting pressure in the shift from the set pressure to unloading.

Unloading pressure are the same as without a vent restrictor.

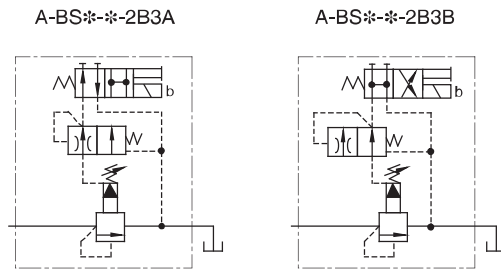

Instructions

- If a remote control relief valve is used in the vent circuit, see [page 203](#). In addition, if the internal volume of the vent line is too large, chattering is likely to occur. Thus, as far as possible reduce the inside diameter and the length of the pipe.
- To adjust the pressure, loosen the lock nut and turn the handle slowly clockwise for higher pressures or anti-clockwise for lower pressures. After adjustments, do not forget to tighten the lock nut.
- Piping of the tank line should not be connected to any tank line of the other valves, but connected directly to the reservoir.
- Pressure is limited by collars fitted. If a working pressure cannot be attained, remove some collars. One collar is equivalent to 10 MPa (1450 PSI).
- With a small flow, the setting pressure may be unstable. Use models numbered 03 and 06 with a flow rate above 8 L/min (2.1 U.S. GPM) and model 10 with 15 L/min (4.0 U.S. GPM).

Interchangeability in Installation between Old and New Design.

Design 48 valve is one on which DSG-01, design 70 is mounted as a pilot valve. It is interchangeable with old design (design 47) with respect to specifications, exterior shape and mounting dimensions.

BST-03-**-**-48/4890
 BST-06-**-**-48/4890
 BST-10-**-**-48/4890

DIMENSIONS IN
 MILLIMETRES (INCHES)

● Terminal Box Type

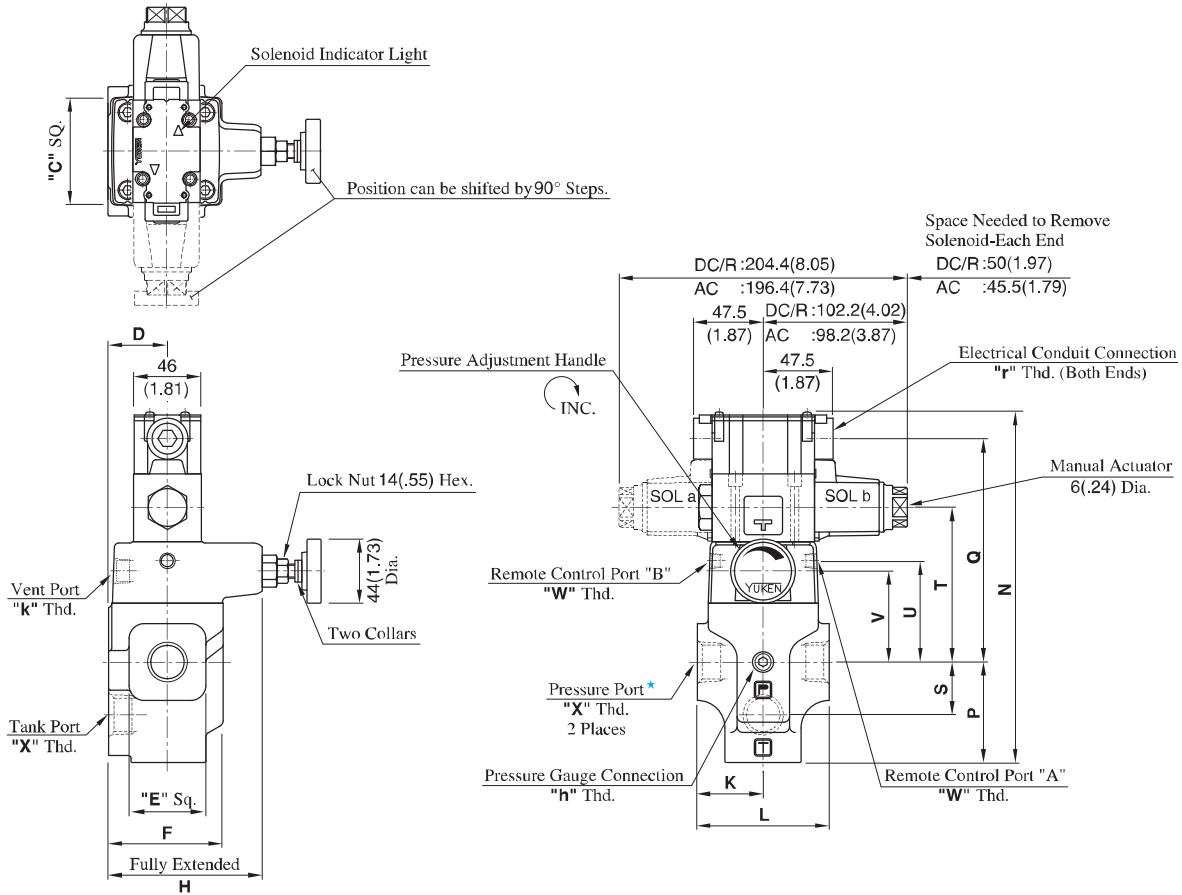

★ There are two threaded connection pressure ports. They can be connected each other in-line; one as inlet and the other as an outlet or the valve can be used by plugging one of the pressure ports.

Model Numbers	Dimensions mm (Inches)													
	C	D	E	F	H	K	L	N	P	Q	S	T	U	V
BST-03-**-48/4890	75 (2.95)	40 (1.57)	52 (2.05)	78 (3.07)	145 (5.71)	45 (1.77)	90 (3.54)	239.3 (9.42)	68.5 (2.70)	152.5 (6.00)	36 (1.42)	105.5 (4.15)	69 (2.72)	62 (2.44)
BST-06-**-48/4890														
BST-10-**-48/4890	85 (3.35)	50 (1.97)	80 (3.15)	96 (3.78)	151 (5.94)	60 (2.36)	120 (4.72)	271.8 (10.70)	89 (3.50)	164.5 (6.48)	49 (1.93)	117.5 (4.63)	81 (3.19)	74 (2.91)

Model Numbers	Japanese Standard "JIS" Design 48					N. American Design Standard Design 4890				
	"W" Thd.	"X" Thd.	"h" Thd.	"k" Thd.	"r" Thd.	"W" Thd.	"X" Thd.	"h" Thd.	"k" Thd.	"r" Thd.
BST-03	Rc 1/8	Rc 3/8	Rc 1/4	Rc 3/8	G 1/2	1/8 NPT	3/8 NPT	1/4 NPT	3/8 NPT	1/2 NPT
BST-06		Rc 3/4					3/4 NPT			
BST-10		Rc 1-1/4					1-1/4 NPT			

C
 Solenoid Controlled Relief Valves

● **Models with Plug-in Connector**

03
BST-06-*-*-N-48/4880/4890
 10

**DIMENSIONS IN
 MILLIMETRES (INCHES)**

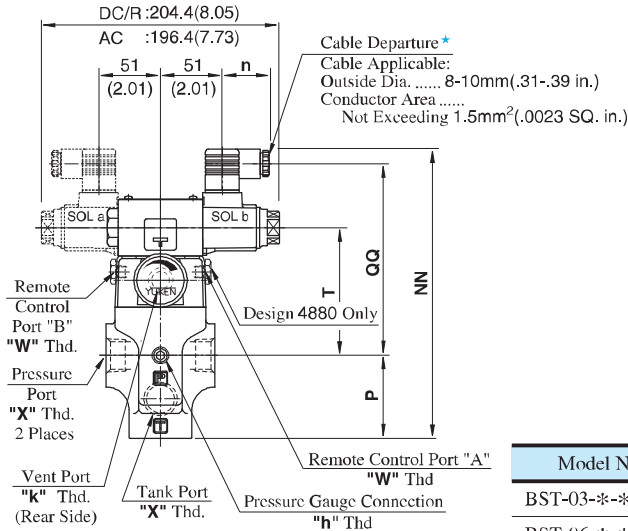

Model Numbers	Dimensions mm(Inches)				
	P	T	NN	QQ	n
BST-03-*-A*-N	68.5 (2.70)	105.5 (4.15)	239 (9.41)	158.5 (6.24)	39 (1.54)
BST-06-*-A*-N					
BST-10-*-A*-N	89 (3.50)	117.5 (4.63)	271.5 (10.69)	170.5 (6.71)	
BST-03-*-D*-N	68.5 (2.70)	105.5 (4.15)	250 (9.84)	169.5 (6.67)	39 (1.54)
BST-06-*-D*-N					
BST-10-*-D*-N	89 (3.50)	117.5 (4.63)	282.5 (11.12)	181.5 (7.15)	
BST-03-*-R*-N	68.5 (2.70)	105.5 (4.15)	253 (9.96)	162.7 (6.41)	53 (2.09)
BST-06-*-R*-N					
BST-10-*-R*-N	89 (3.50)	117.5 (4.63)	285.5 (11.24)	174.7 (6.88)	

★ Position of cable departure can be changed. For details, refer to DSG-01 valve on [page 357](#).

Model Numbers	"W" Thd.	"X" Thd.	"h" Thd.	"k" Thd.
BST-03-*-*-N-4880		3/8 BSP.F		
BST-06-*-*-N-4880	1/8 BSP.F	3/4 BSP.F	1/4 BSP.Tr	3/8 BSP.Tr
BST-10-*-*-N-4880		1-1/4 BSP.F		

See the installation drawing of terminal box type on [page 223](#) for design 48 and 4890 port thread and other dimensions.

■ **Options - Models with Vent Restrictor**

● **Terminal Box Type**

03
A-BST-06-*-2B3A
10 2B3B-*-48/4880

● **Plug-in Connector Type**

03
A-BST-06-*-2B3A
10 2B3B-*-N-48/4880/4890

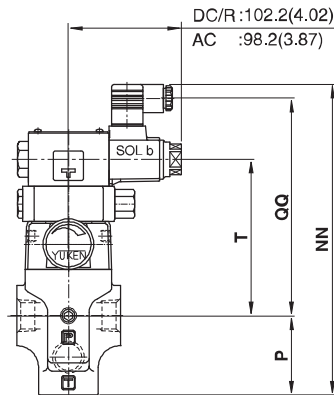
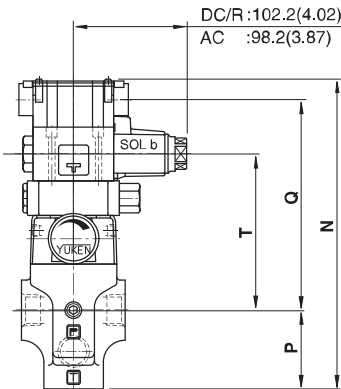

Model Numbers	Dimensions mm (Inches)		Terminal Box Type		Plug-in Connector Type					
	P	T	N	Q	AC Solenoid		DC Solenoid		R (AC→DC) Solenoid	
					NN	QQ	NN	QQ	NN	QQ
A-BST-03	68.5 (2.70)	135.5 (5.33)	269.3 (10.60)	182.5 (7.19)	269 (10.59)	188.5 (7.42)	280 (11.02)	199.5 (7.85)	283 (11.14)	192.7 (7.59)
A-BST-06										
A-BST-10	89 (3.50)	147.5 (5.81)	301.8 (11.88)	194.5 (7.66)	301.5 (11.87)	200.5 (7.89)	312.5 (12.30)	211.5 (8.33)	315.5 (12.42)	204.7 (8.06)

For other dimensions, see the models without vent restrictor type on [page 223](#) and [224](#).

BSG-03-***-48/4890
 BSG-06-***-48/4890
 BSG-10-***-48/4890

Mounting surface
 BSG-03: ISO 6264-AR-06-2-A
 BSG-06: ISO 6264-AS-08-2-A
 BSG-10: ISO 6264-AT-10-2-A

● Terminal Box Type

DIMENSIONS IN
MILLIMETRES (INCHES)

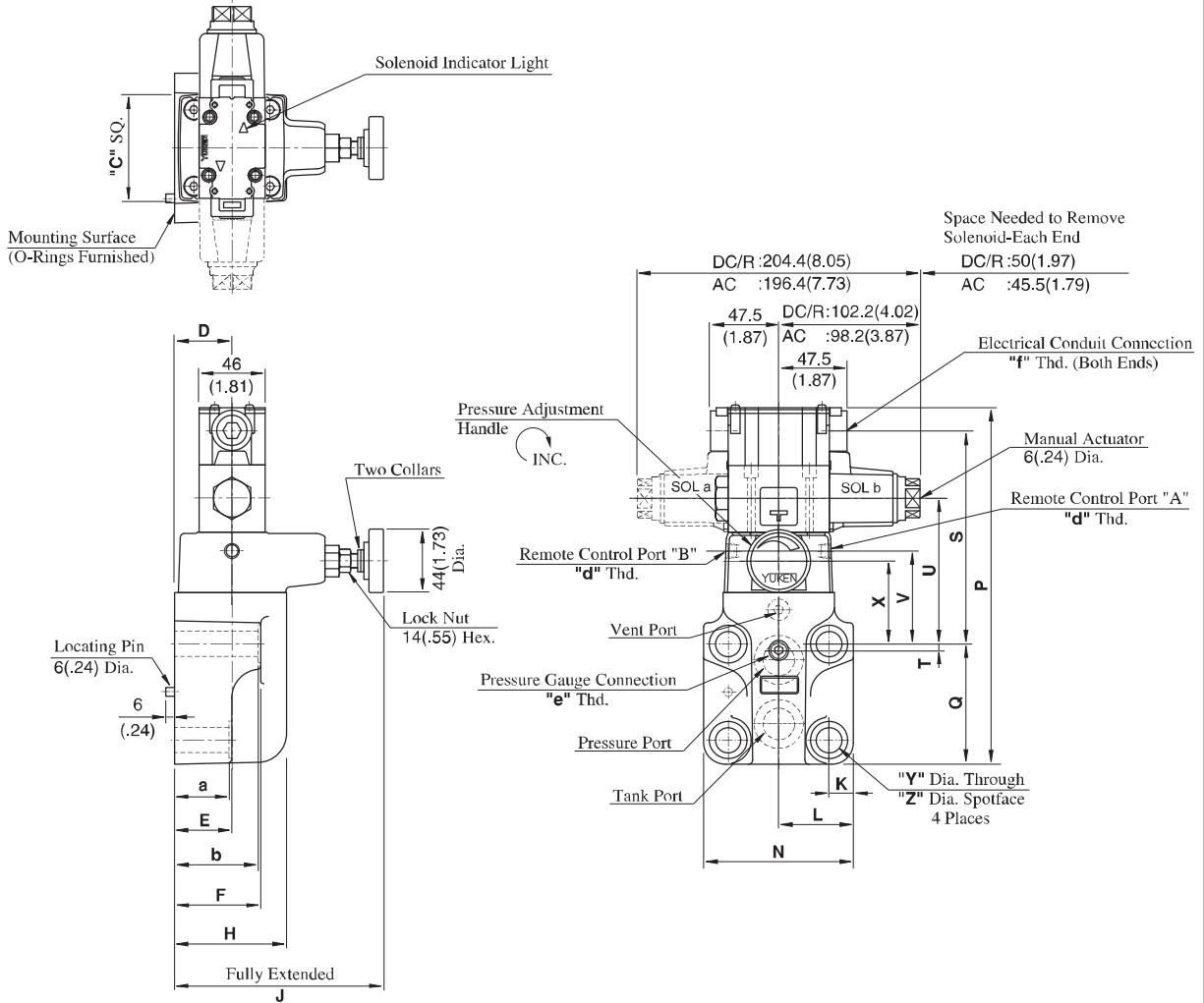

Model Numbers	Dimensions mm (Inches)																			
	C	D	E	F	H	J	K	L	N	P	Q	S	T	U	V	X	Y	Z	a	b
BSG-03	75 (2.95)	40 (1.57)	57 (2.24)	78 (3.07)	78 (3.07)	145 (5.71)	14.1 (.56)	41 (1.61)	82 (3.23)	225.8 (8.89)	77 (3.03)	130.5 (5.14)	22 (.87)	83.5 (3.29)	47 (1.85)	40 (1.57)	13.5 (.53)	21 (.83)	55 (2.17)	77 (3.03)
BSG-06	75 (2.95)	40 (1.57)	40 (1.57)	60 (2.36)	78 (3.07)	145 (5.71)	17 (.67)	52 (2.05)	104 (4.09)	249.8 (9.83)	83.5 (3.29)	148 (5.83)	4.5 (.18)	101 (3.98)	64.5 (2.54)	57.5 (2.26)	17.5 (.69)	26 (1.02)	38 (1.50)	58 (2.28)
BSG-10	85 (3.35)	45 (1.77)	47 (1.85)	67 (2.64)	84 (3.31)	146 (5.75)	20.7 (.81)	62 (2.44)	124 (4.88)	283.8 (11.17)	110 (4.33)	155.5 (6.12)	6 (.24)	108.5 (4.27)	72 (2.83)	65 (2.56)	21.5 (.85)	32 (1.26)	45 (1.77)	65 (2.56)

Model Numbers	Japanese Standard "JIS" Design 48			N. American Design Standard Design 4890		
	"d" Thd.	"e" Thd.	"f" Thd.	"d" Thd.	"e" Thd.	"f" Thd.
BSG-03						
BSG-06	Rc 1/8	Rc 1/4	G 1/2	1/8 NPT	1/4 NPT	1/2 NPT
BSG-10						

Note: For dimensions of the valve mounting surface, see the installation drawing (P. 213) of the sub-plate used together.

C
Solenoid Controlled Relief Valves

● **Models with Plug-in Connector**

03
BSG-06-*-N-48/4880/4890
10

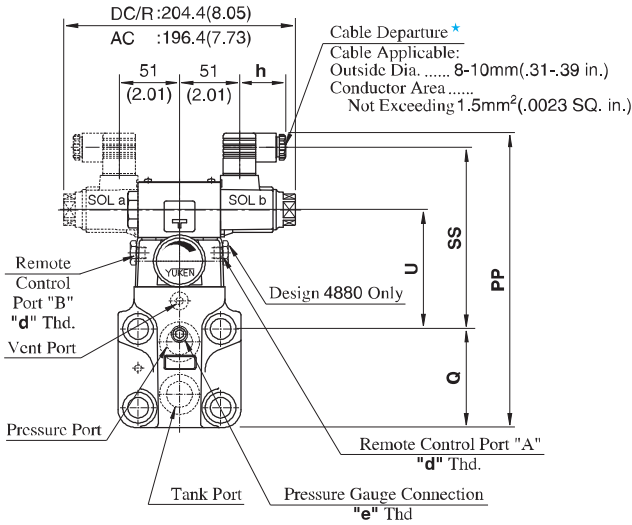

★ Position of cable departure can be changed. For details, refer to DSG-01 valve on page 357.

DIMENSIONS IN MILLIMETRES (INCHES)

■ **Options - Models with Vent Restrictor**

● **Terminal Box Type**

03
A-BSG-06-*-2B3A-*-48/4890
10
2B3B

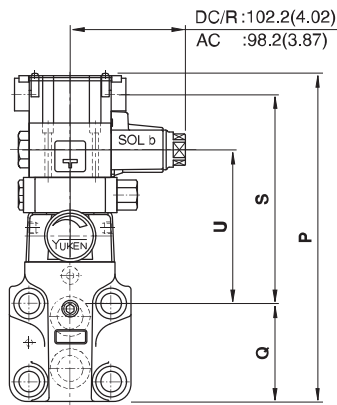

● **Plug-in Connector Type**

03
A-BSG-06-*-2B3A-*-N-48/4880/4890
10
2B3B

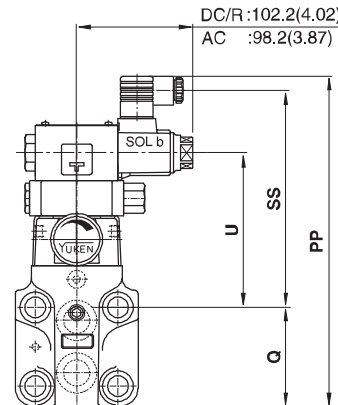

Model Numbers	Dimensions mm(Inches)				
	Q	U	PP	SS	h
BSG-03-*-A*-N	77 (3.03)	83.5 (3.29)	225.5 (8.88)	136.5 (5.37)	39 (1.54)
BSG-06-*-A*-N	83.5 (3.29)	101 (3.98)	249.5 (9.82)	154 (6.06)	
BSG-10-*-A*-N	110 (4.33)	108.5 (4.27)	283.5 (11.16)	161.5 (6.36)	
BSG-03-*-D*-N	77 (3.03)	83.5 (3.29)	236.5 (9.31)	147.5 (5.81)	39 (1.54)
BSG-06-*-D*-N	83.5 (3.29)	101 (3.98)	260.5 (10.26)	165 (6.50)	
BSG-10-*-D*-N	110 (4.33)	108.5 (4.27)	294.5 (11.59)	172.5 (6.79)	
BSG-03-*-R*-N	77 (3.03)	83.5 (3.29)	239.5 (9.43)	140.7 (5.54)	53 (2.09)
BSG-06-*-R*-N	83.5 (3.29)	101 (3.98)	263.5 (10.37)	158.2 (6.23)	
BSG-10-*-R*-N	110 (4.33)	108.5 (4.27)	297.5 (11.71)	165.7 (6.52)	

Model Numbers	"d" Thd.	"e" Thd.
BSG-03-*-N-4880	1/8 BSP.F	1/4 BSP.Tr
BSG-06-*-N-4880		
BSG-10-*-N-4880		

See the installation drawing of terminal box type on page 225 for design 48 and 4890 port threads and other dimensions.

Model Numbers	Dimensions mm (Inches)		Plug-in Connector Type							
	Q	U	Terminal Box Type		AC Solenoid		DC Solenoid		R (AC→DC) Solenoid	
			P	S	PP	SS	PP	SS	PP	SS
A-BSG-03	77 (3.03)	113.5 (4.47)	255.8 (10.07)	160.5 (6.32)	255.5 (10.06)	166.5 (6.56)	266.5 (10.49)	177.5 (6.99)	269.5 (10.61)	170.7 (6.72)
A-BSG-06	83.5 (3.29)	131 (5.16)	279.8 (11.02)	178 (7.01)	279.5 (11.00)	184 (7.24)	290.5 (11.44)	195 (7.68)	293.5 (11.56)	188.2 (7.41)
A-BSG-10	110 (4.33)	138.5 (5.45)	313.8 (12.35)	185.5 (7.30)	313.5 (12.34)	191.5 (7.54)	324.5 (12.78)	202.5 (7.97)	327.5 (12.89)	195.7 (7.70)

For other dimensions, see the models without vent restrictor type on page 225 and 226.

Spare Parts List

Threaded Connections

Terminal Box Type

03
BST-06-***-48/4890
10

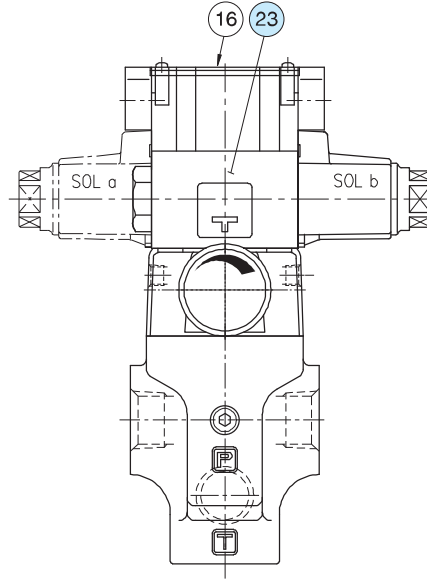
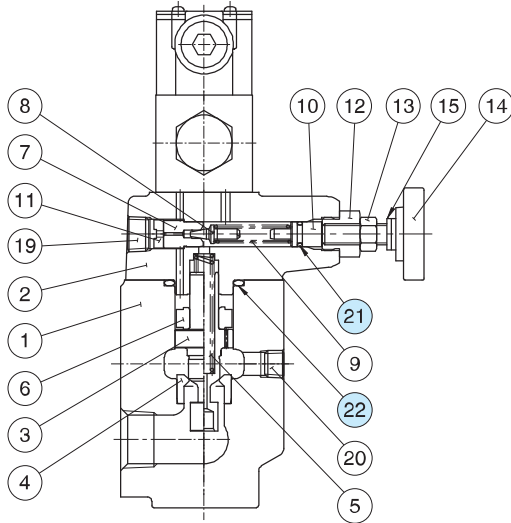

Models with Plug-in Connector

03
BST-06-***-N-48/4880/4890
10

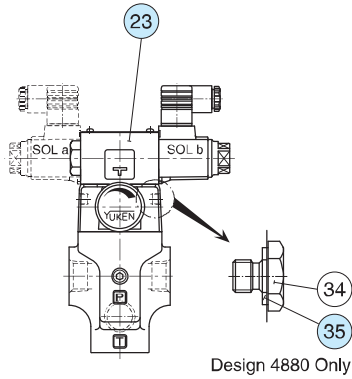

Option

Models with Vent Restrictor

03
A-BST-06-***-48/4890
10
N-48/4880/4890

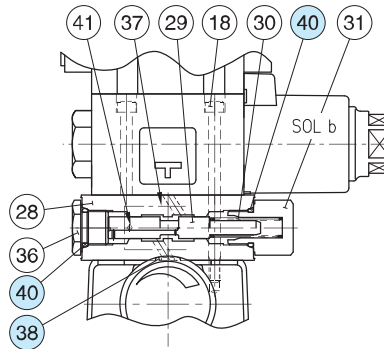

List of Seals

Item	Name of Parts	Part Numbers			Qty.
		BST-03	BST-06	BST-10	
21	O-Ring	SO-NA-P9	SO-NA-P9		1
22	O-Ring	SO-NB-P32	SO-NB-P42		1
35	Bonded Seal	SG-FB-1/8	SG-FB-1/8		2
38*	O-Ring		SO-NB-P8		2
40*	O-Ring		SO-NB-P14		2

★ The O-Rings for Item 38,40 are used only for the models with the vent restrictor.

Note: When ordering the seals, please specify the seal kit number from the table right. In addition to the above seals, seals for the pilot valves are included in the seal kit.

For the detail of the pilot valve seals, see the page 359.

List of Seal Kits

Valve Model Numbers	Seal Kit Numbers
BST-03	KS-BST-03-48
BST-06	
BST-10	KS-BST-10-48
A-BST-03	KS-A-BST-03-48
A-BST-06	
A-BST-10	KS-A-BST-10-48

Note: No bonded seals are included in the seal kits.

Pilot Valves

See page 229 for the pilot valve model numbers to be used.

■ Spare Parts List

■ Sub-plate Mounting

● Terminal Box Type

03
BSG-06-***-48/4890
10

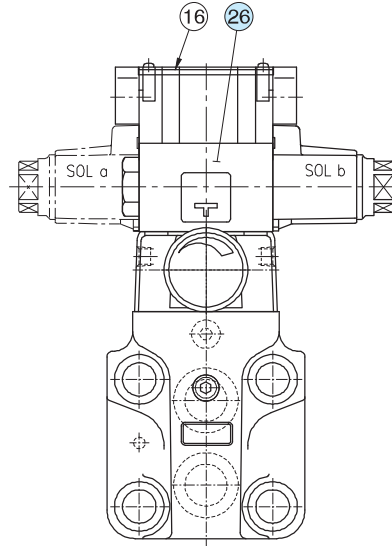
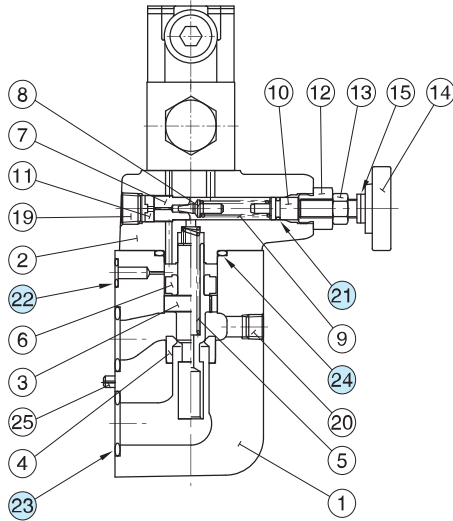

● Models with Plug-in Connector

03
BSG-06-***-N-48/4880/4890
10

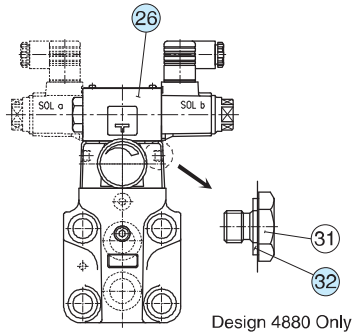

■ Option

● Models with Vent Restrictor

03
A-BSG-06-***-48/4890
10
N-48/4880/4890

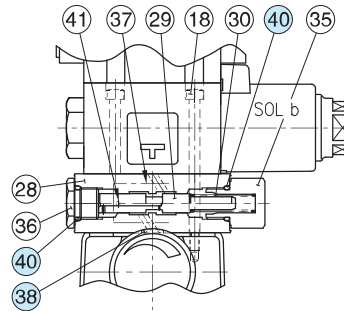

● List of Seals

Item	Name of Parts	Part Numbers			Qty.
		BSG-03	BSG-06	BSG-10	
21	O-Ring	SO-NA-P9	SO-NA-P9	SO-NA-P9	1
22	O-Ring	SO-NB-P9	SO-NB-P11	SO-NB-P9	1
23	O-Ring	SO-NB-P18	SO-NB-P28	SO-NB-P32	2
24	O-Ring	SO-NB-P32	SO-NB-P32	SO-NB-P42	1
32	Bonded Seal	SG-FB-1/8	SG-FB-1/8	SG-FB-1/8	2
38*	O-Ring		SO-NB-P8		2
40*	O-Ring		SO-NB-P14		2

★ The O-Rings for item 38, 40 are used only for the models with the vent restrictor.

Note: When ordering the seals, please specify the seal kit number from the table right. In addition to the above seals, seals for the pilot valves are included in the seal kit.

For the detail of the pilot valve seals, see [page 359](#).

● List of Seal Kits

Valve Model Numbers	Seal Kit Numbers
BSG-03	KS-BSG-03-48
BSG-06	KS-BSG-06-48
BSG-10	KS-BSG-10-48
A-BSG-03	KS-A-BSG-03-48
A-BSG-06	KS-A-BSG-06-48
A-BSG-10	KS-A-BSG-10-48

Note: No bonded seals are included in the seal kits.

● Pilot Valves

See [page 229](#) for the pilot valve model numbers to be used.

■ Spare Parts List

● List of Pilot Valves

Type of Electrical Conduit Connection	Valve Model Numbers	Pilot Valve Model Numbers	Remarks
Terminal Box Type	*-BST/BSG-03/06/10-*2B3A-★-48	DSG-01-2B3A-★-70	Japanese Standard "JIS"
	*-BST/BSG-03/06/10-*2B3B-★-48	DSG-01-2B3B-★-70	
	*-BST/BSG-03/06/10-*2B2B-★-48	DSG-01-2B2B-★-70	
	*-BST/BSG-03/06/10-*2B2-★-48	DSG-01-2B2-★-70	
	*-BST/BSG-03/06/10-*3C2-★-48	DSG-01-3C2-★-70	
	*-BST/BSG-03/06/10-*3C3-★-48	DSG-01-3C3-★-70	
	*-BST/BSG-03/06/10-*2B3A-★-4890	DSG-01-2B3A-★-7090	N. American Design Std.
	*-BST/BSG-03/06/10-*2B3B-★-4890	DSG-01-2B3B-★-7090	
	*-BST/BSG-03/06/10-*2B2B-★-4890	DSG-01-2B2B-★-7090	
	*-BST/BSG-03/06/10-*2B2-★-4890	DSG-01-2B2-★-7090	
	*-BST/BSG-03/06/10-*3C2-★-4890	DSG-01-3C2-★-7090	
	*-BST/BSG-03/06/10-*3C3-★-4890	DSG-01-3C3-★-7090	
Plug-in Connector Type	*-BST/BSG-03/06/10-*2B3A-★-N-48	DSG-01-2B3A-★-N-70	Japanese Standard "JIS"
	*-BST/BSG-03/06/10-*2B3B-★-N-48	DSG-01-2B3B-★-N-70	
	*-BST/BSG-03/06/10-*2B2B-★-N-48	DSG-01-2B2B-★-N-70	
	*-BST/BSG-03/06/10-*2B2-★-N-48	DSG-01-2B2-★-N-70	
	*-BST/BSG-03/06/10-*3C2-★-N-48	DSG-01-3C2-★-N-70	
	*-BST/BSG-03/06/10-*3C3-★-N-48	DSG-01-3C3-★-N-70	
	*-BST/BSG-03/06/10-*2B3A-★-N-4880	DSG-01-2B3A-★-N-70	European Design Std.
	*-BST/BSG-03/06/10-*2B3B-★-N-4880	DSG-01-2B3B-★-N-70	
	*-BST/BSG-03/06/10-*2B2B-★-N-4880	DSG-01-2B2B-★-N-70	
	*-BST/BSG-03/06/10-*2B2-★-N-4880	DSG-01-2B2-★-N-70	
	*-BST/BSG-03/06/10-*3C2-★-N-4880	DSG-01-3C2-★-N-70	
	*-BST/BSG-03/06/10-*3C3-★-N-4880	DSG-01-3C3-★-N-70	
	*-BST/BSG-03/06/10-*2B3A-★-N-4890	DSG-01-2B3A-★-N-7090	N. American Design Std.
	*-BST/BSG-03/06/10-*2B3B-★-N-4890	DSG-01-2B3B-★-N-7090	
	*-BST/BSG-03/06/10-*2B2B-★-N-4890	DSG-01-2B2B-★-N-7090	
	*-BST/BSG-03/06/10-*2B2-★-N-4890	DSG-01-2B2-★-N-7090	
	*-BST/BSG-03/06/10-*3C2-★-N-4890	DSG-01-3C2-★-N-7090	
	*-BST/BSG-03/06/10-*3C3-★-N-4890	DSG-01-3C3-★-N-7090	

Note: 1. Fill a coil type (a symbol representing current/voltage) in section marked ★.

2. For the details of the pilot valves, see [page 359](#).

